



Project _____

AIA# _____ SIS# _____

Item # _____ Quantity _____

MODELS

Multiple Turbo

STANDARD FEATURES

- External and internal sheet metal parts in stainless steel.
- 17 lbs fryer with snap action thermostat, 212 -400°F (100 - 204°C) temperature range.
- 3/4" thick polished cold rolled steel plate, fully welded to frame to prevent grease collection.
- Reversible top cast iron grate with two levels.
- 30,000 BTU/hr 4 open burners.
- Removable stainless steel grease trays, for fast cleaning.
- Large oven with two nickel-plated grills with integrated safety valve thermostat, 212-572°F (100-300°C) temperature range.
- Individual stainless steel no clog pilots.
- Zamak die cast knobs with set screws.
- Gas pressure regulator.
- 4" stainless steel adjustable legs.
- CSA design certified, NSF listed.

MASTER SERIES

Multiple Turbo Gas Range



Model Multiple Turbo

The images presented here are illustrative and may vary or not exactly match the physical product.

MASTER SERIES - Multiple Turbo Gas Range



DESCRIPTION

Multiple Turbo Gas Range is the all-in-one cooking suite specially designed to solve the needs of the culinary entrepreneur. Thanks to its hygienic monoblock top made of one piece of stainless steel reduces cleaning time and lowers maintenance costs.

SPECIFY TYPE OF GAS WHEN ORDERING

- Natural Gas
- Propane

SPECIFY ALTITUD

Above 2,000 ft

Approved by _____ Date Approved by _____ Date _____



MASTER SERIES

Multiple Turbo Gas Ranges

CLEARANCE AND POSITIONING REQUIREMENTS

This product must be installed on a non-combustible surface only, with a minimum of 6" from all sides. There must be a clearance of at least 6" from another appliance. This unit is supplied with 4 legs and must be placed on a resistant non-slip surface.

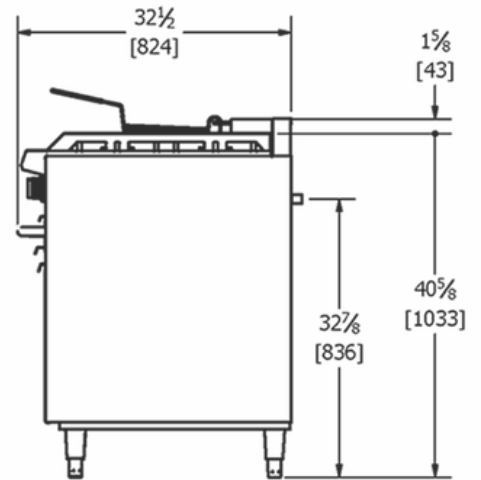
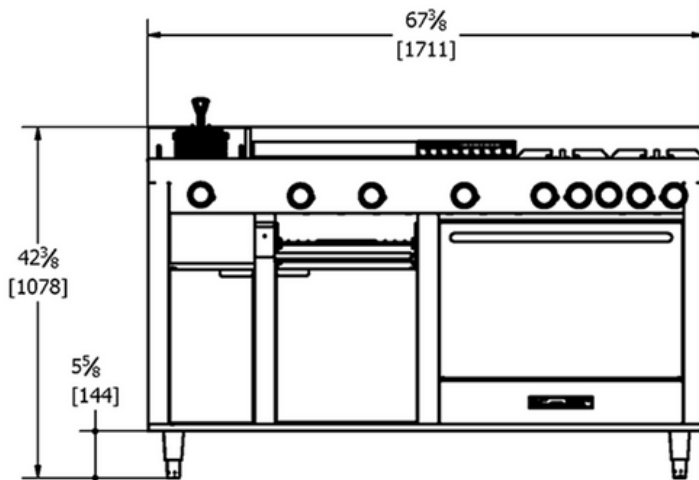

Top View	Model	Description	Total Input BTU/hr	Shipping Weight (Lbs/Kg)
	Multiple Turbo Master	1 Fryer (17 lbs) /1 Manual Griddle/ 1 Lava Rock Charbroiler/ 4 open burners/1 Cheesemelter/ 1 Standard Oven 26" X 23 1/4" x 16 1/2"	217,000	776/352