

## FREIDORAS A GAS

**ATFS-40**



**ATFS-50**



**ATFS-75**



### Características:

- Freidor a gas.
- Frente y costados en a.inox. 430.
- Interior y respaldo posterior en lámina de a.alum.
- Tina a.inox. 430.
- 2 canastillas.
- Zona fría al fondo.
- Quemadores en FO.FO. de 30,000 BTU/H, c/u.
- Termostato RX de acción instantánea, rango de 100 a 204°C.
- Válvula de seguridad electromecánica "millivolt".
- Control "high limit" de protección térmica calibrado a 232°C.
- Parrilla de alambro para apoyar canastillas.
- Válvula de drenado de 1 1/4" de Ø en la parte baja.
- 2 ruedas delanteras con freno y 2 ruedas traseras locas.
- Incluye espreas para conversión de gas GLP a GN.





• INFORMACIÓN TÉCNICA:

MODELO	QUEMADORES	B.T.U./h	CAPACIDAD LT	MEDIDAS DE TINA	MEDIDAS DE CANASTILLA	FRENTE	FONDO	ALTO	PESO
<b>ATFS-40</b>	3	90,000	19.5 litros	0.35x0.35x0.17 m	0.17x0.33x0.16m	0.396 m	0.764 m	1.127 m	59 Kg
<b>ATFS-50</b>	4	24.5 litros	0.35x0.35x0.17 m	0.17x0.33x0.16m	0.396 m	0.764 m	1.127 m	77 Kg	
<b>ATFS-75</b>	5	150,000	37.5 litros	0.53x0.35x0.17 m	0.23x0.33x0.16m	0.535 m	0.764 m	1.127 m	90 Kg

• VISTA FRONTAL

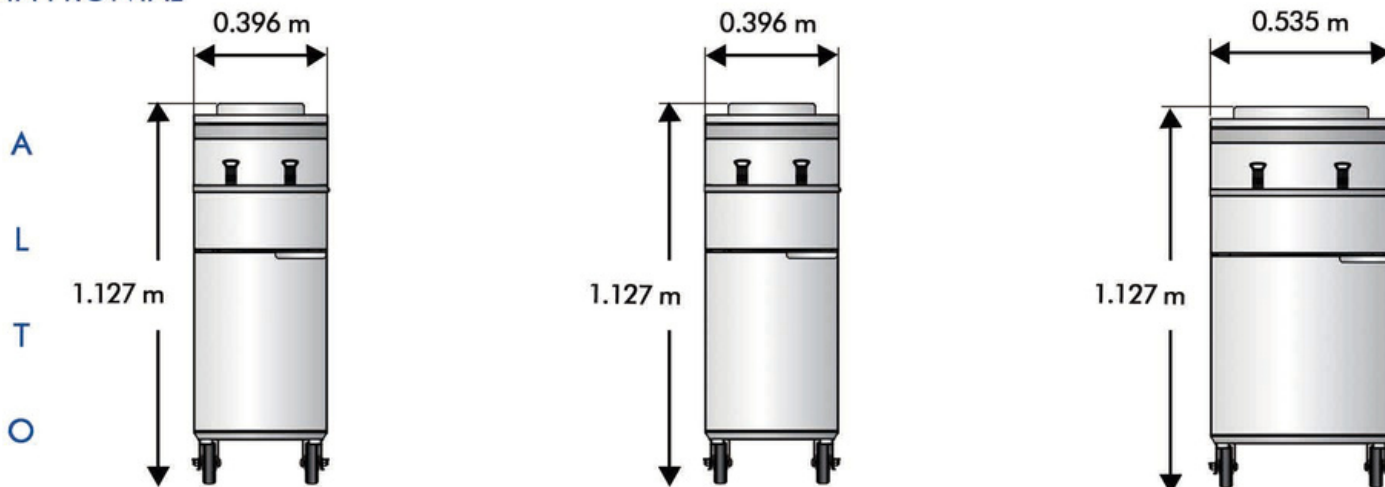

• VISTA TOP

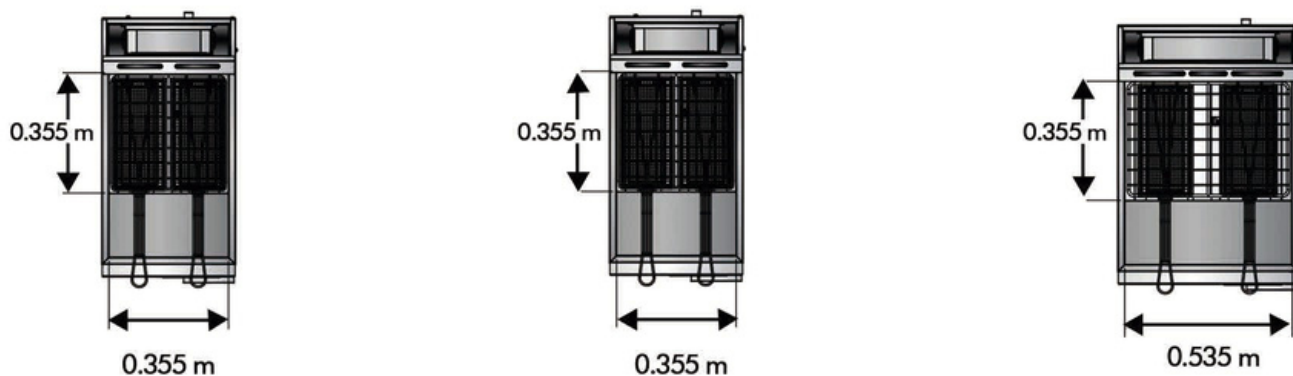

• VISTA LATERAL

