

CONGELADORES VERTICALES PUERTAS SÓLIDAS TOP MOUNT SERIES



MBF8001GR



MBF8002GR



MBF8003GR

Características:

- Congeladores verticales, con puertas sólidas.
- Unidad de refrigeración en zona superior.
- Frente, costados e interior en a.inox. 430.
- Respaldo posterior externo en a.alum.
- Interior con curvas sanitarias NSF.
- Puertas sólidas con cerradura.
- Puertas con: "autocierre" y "mantener puertas abierta".
- Parrillas plastificadas en el interior.
- Iluminación interna.
- Enfriamiento por aire forzado.
- Paro de ventilador al abrir la puerta.
- 1 control digital de temperatura.
- Deshielo automático y manual.
- Rango de temperatura de -18 a -22°C.
- 2 ruedas delanteras con freno y 2 ruedas traseras locas.
- Certificados NSF, UL, CSA & NOM.
- Certificado eficiencia ENERGY STAR®.



• INFORMACIÓN TÉCNICA:

| MODELO | CAP. PIES ³ | PUERTAS | COMPRESOR | VOLTAJE | POTENCIA | CORRIENTE | PESO | FRENTE | FONDO | ALTO |
|------------------|------------------------|---------|-----------|-----------|----------|-----------|--------|---------|---------|---------|
| MBF8001GR | 21.4 | 1 | 1/2 HP | 127V/60Hz | 610 W | 6.3 A | 102 Kg | 0.730 m | 0.805 m | 2.065 m |
| MBF8002GR | 43.1 | 2 | 3/4 HP | 127V/60Hz | 935 W | 8.6 A | 160 Kg | 1.314 m | 0.805 m | 2.065 m |
| MBF8003GR | 64.9 | 3 | 1 HP | 127V/60Hz | 1200 W | 5.5 A | 200 Kg | 1.976 m | 0.805 m | 2.130 m |

F R E N T E

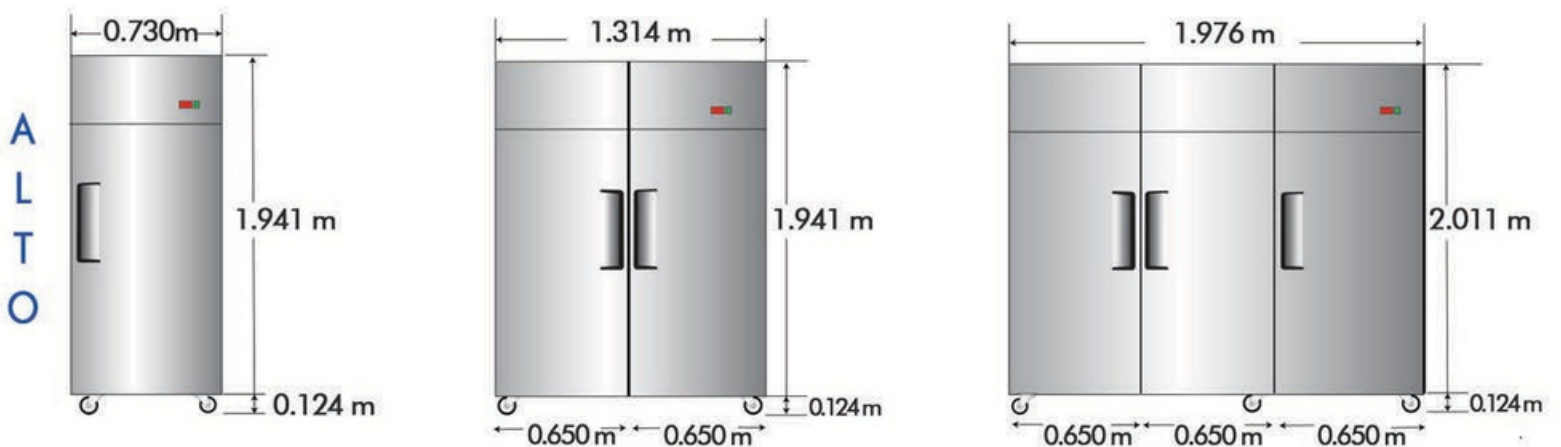

• PUERTAS ABIERTAS

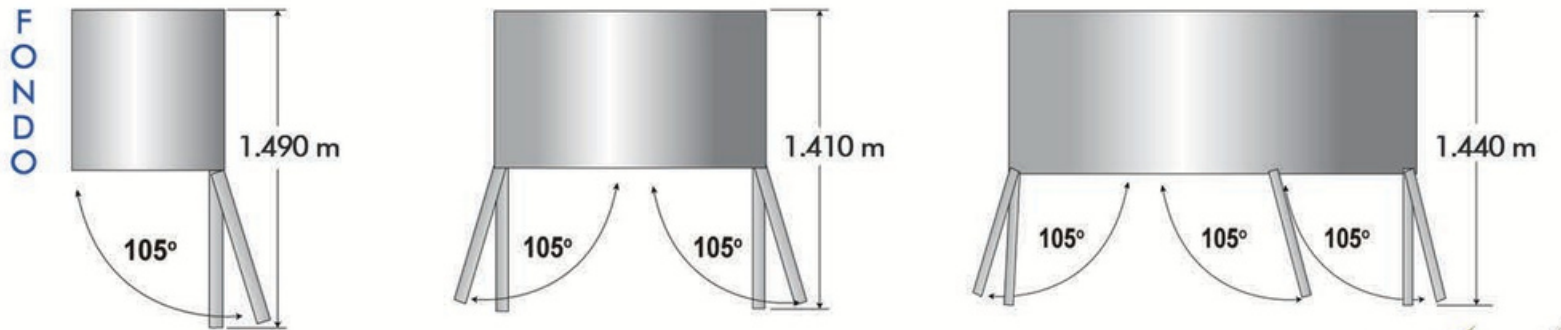

• DIMENSIONES INTERIORES

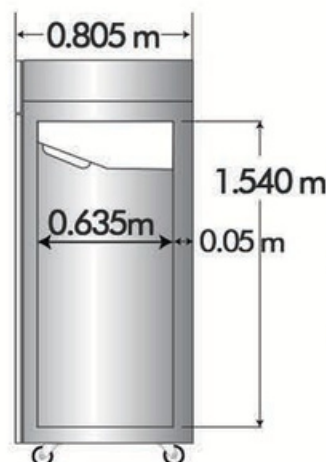

A L T O

