



• WDF097D



• WDF127D



• WDF157D

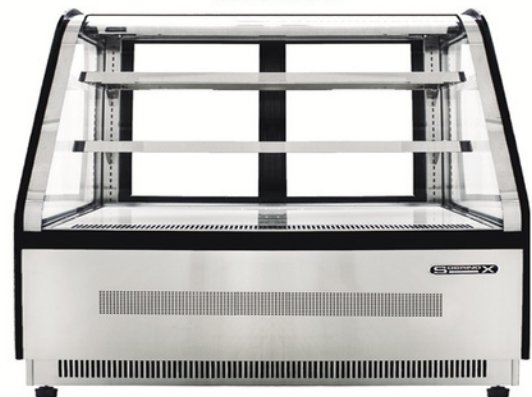

• WDF177D



Características:

- Vitrina refrigerada de piso curva.
- Frente de doble cristal curvo.
- Laterales de cristal.
- Estructura inferior fabricada en a.inox. 430.
- Exterior en acero tipo 304.
- 3 repisas de cristal.
- Iluminación LED.
- Enfriamiento por aire forzado.
- Deshielo automático y manual.
- 1 condensador dinámico.
- 1 control digital de temperatura.
- Rango de temperatura de 0 a 8 °C.
- 4 niveladores de altura.
- 127 V, 60 Hz,



• INFORMACIÓN TÉCNICA:

MODELO	CAP. Lt.	COMPRESOR	PUERTAS	VOLTAJE	POTENCIA	CORRIENTE	PESO	FRENTE	FONDO	ALTO
WDF097D	269	1/4 HP	2	127V/60Hz	530 W	2.8 A	174 Kg	0.900 m	0.750 m	1.350 m
WDF127D	365	1/6 HP	2	127V/60Hz	740 W	3.6 A	261 Kg	1.200 m	0.750 m	1.350 m
WDF157D	552	3/4 HP	2	127V/60Hz	830 W	4.2 A	241 Kg	1.500 m	0.750 m	1.350 m
WDF177D	631	3/4 HP	3	127V/60Hz	950 W	5 A	255 Kg	1.700 m	0.750 m	1.350 m

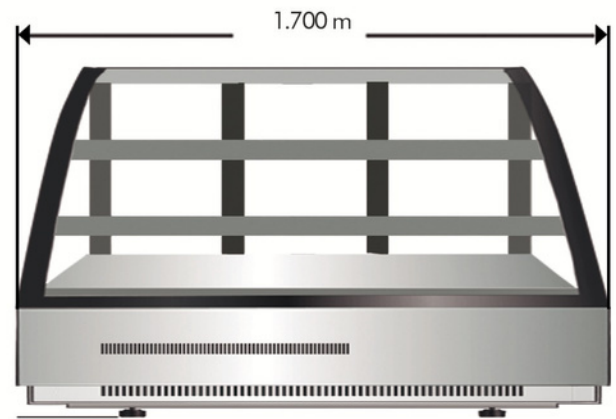
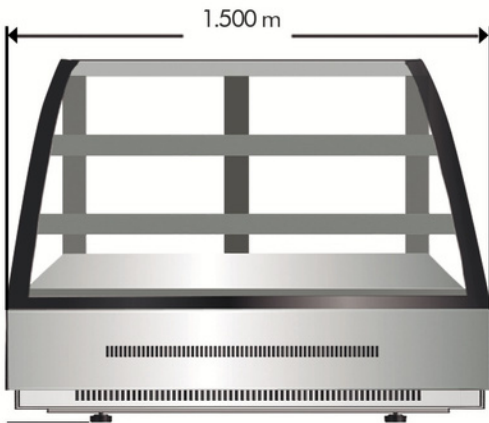
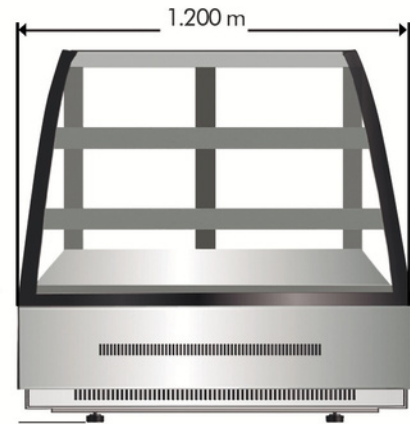
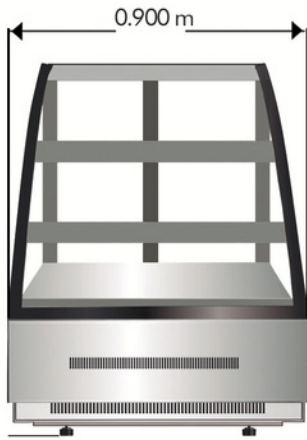

NOM