

ENFRIADORES VERTICALES PUERTA DE CRISTAL



• CTD-3



• CTD-3S



• CTD-5

Características:

- Enfriador vertical, con 1 puerta de cristal.
- Gabinete en acero con esmalte negro.
- Interiores de plástico.
- Respaldo posterior externo en a.alum.
- 1 puerta de cristal.
- Parrillas plastificadas en el interior.
- Iluminación LED.
- 1 condensador estático.
- 1 compresor con refrigerante ecológico.
- Rango de temperatura de 1 a 6°C.
- Certificados NSF, UL, CSA & NOM.





• INFORMACIÓN TÉCNICA:

MODELO	CAP. PIES ³	PARRILLAS	VOLTAJE	POTENCIA	CORRIENTE	PESO	FRENTE	FONDO	ALTO
CTD-3	2.4	3	127 V/60Hz	260 W	1.5 A	24 Kg	0.438 m	0.500 m	0.698 m
CTD-3S	2.4	3	127 V/60Hz	260 W	1.5 A	29 Kg	0.472 m	0.500 m	0.840 m
CTD-5	4.5	4	127 V/60Hz	320 W	1.7 A	40 Kg	0.542 m	0.571 m	0.860 m

• VISTA FRONTAL

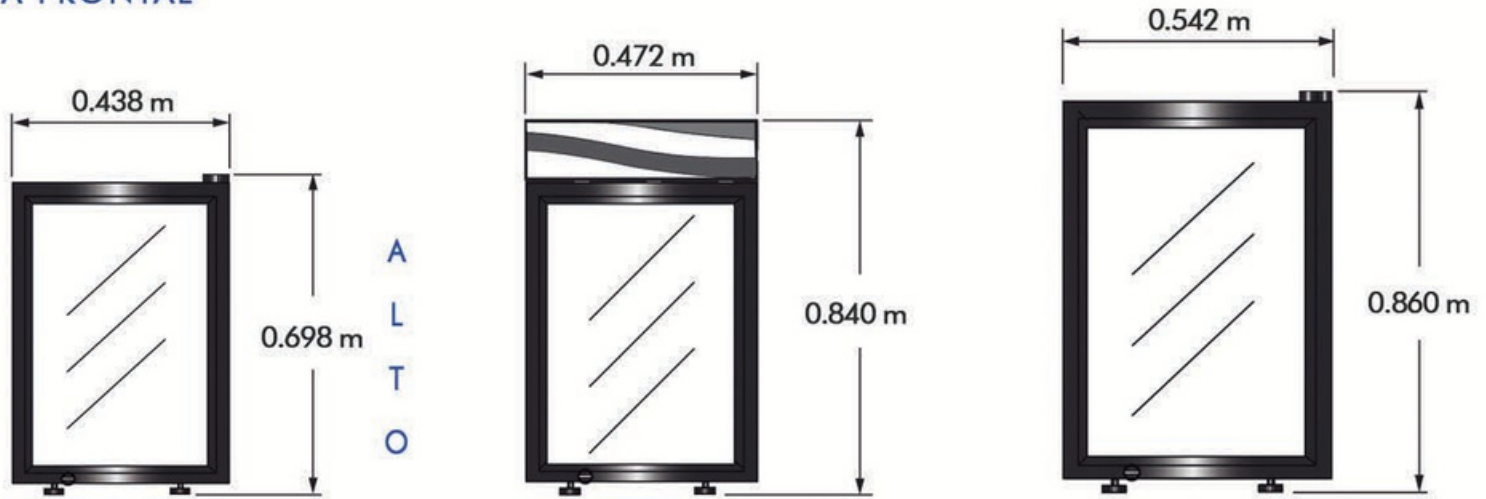

• VISTA TOP

