

875S RETAIL COFFEE GRINDERS

Models

875S (875-BS)

875S (875-RS)



model 875S (875-BS)



model 875S (875-RS)

Features

- Compact and powerful retail coffee grinders.
- Space-saving size of only 7" (18 cm) wide, with a fast grind speed and powerful, energy-efficient 0.5 hp motor to make quick work of coffee beans.
- Motor includes circuit breaker.
- Ideal for low to medium volume specialty shops, grocery stores, doughnut shops, and c-stores.
- Precision burrs guaranteed to process 40,000 lbs. (18,144 kg) of coffee at medium grind.
- Exceptional warranty program: burrs - 4 years or 40,000 lbs. (18,144 kg) of coffee, all other components - 2 years.
- Multiple grind particle profile selections.

875S RETAIL COFFEE GRINDERS

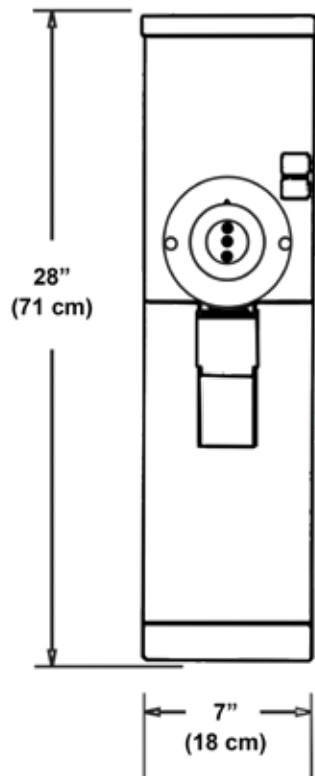

Front View

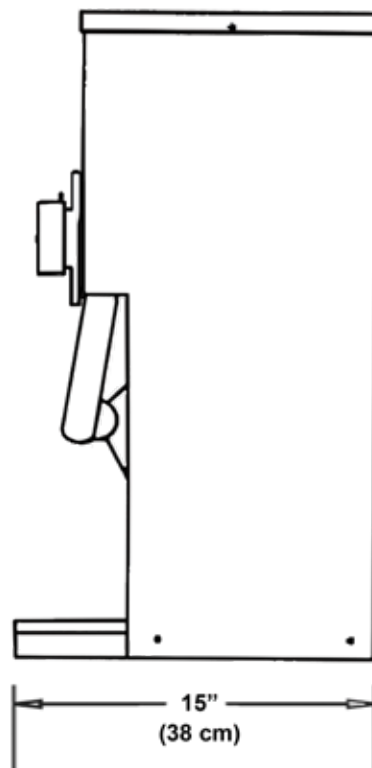

Side View



MODEL	DESCRIPTION	ELECTRICAL	PRODUCT DIMENSIONS (H X W X D)	SHIPPING DIMENSIONS (H X W X D)	SHIP WEIGHT
875S (875-BS)	Black with 3 lbs. (1.4 kg) hopper	115V / 0.92 kW / 8A / 1 Ph NEMA 5-15P line cord included.	28" x 7" x 15" (71 cm x 18 cm x 38 cm)	32" x 10.75" x 19.5" (81 cm x 27 cm x 50 cm)	48 lbs. (21.8 kg)
875S (875-RS)	Red with 3 lbs. (1.4 kg) hopper	115V / 0.92 kW / 8A / 1 Ph NEMA 5-15P line cord included.	28" x 7" x 15" (71 cm x 18 cm x 38 cm)	32" x 10.75" x 19.5" (81 cm x 27 cm x 50 cm)	48 lbs. (21.8 kg)